

## Sky Climber Model: ISA-BUT-SKT-BLT-2

Application: SS Threaded ISA Button + Drop-In Anchor for Post-Installed Connections In Concrete

- ALL STAINLESS STEEL ISA RECEIVER AND DROP-IN ANCHOR
- DESIGNED TO SUPPORT A 600 LB LOAD IN ANY DIRECTION
- NYDOL COMPLIANT BUTTON HEAD DESIGN

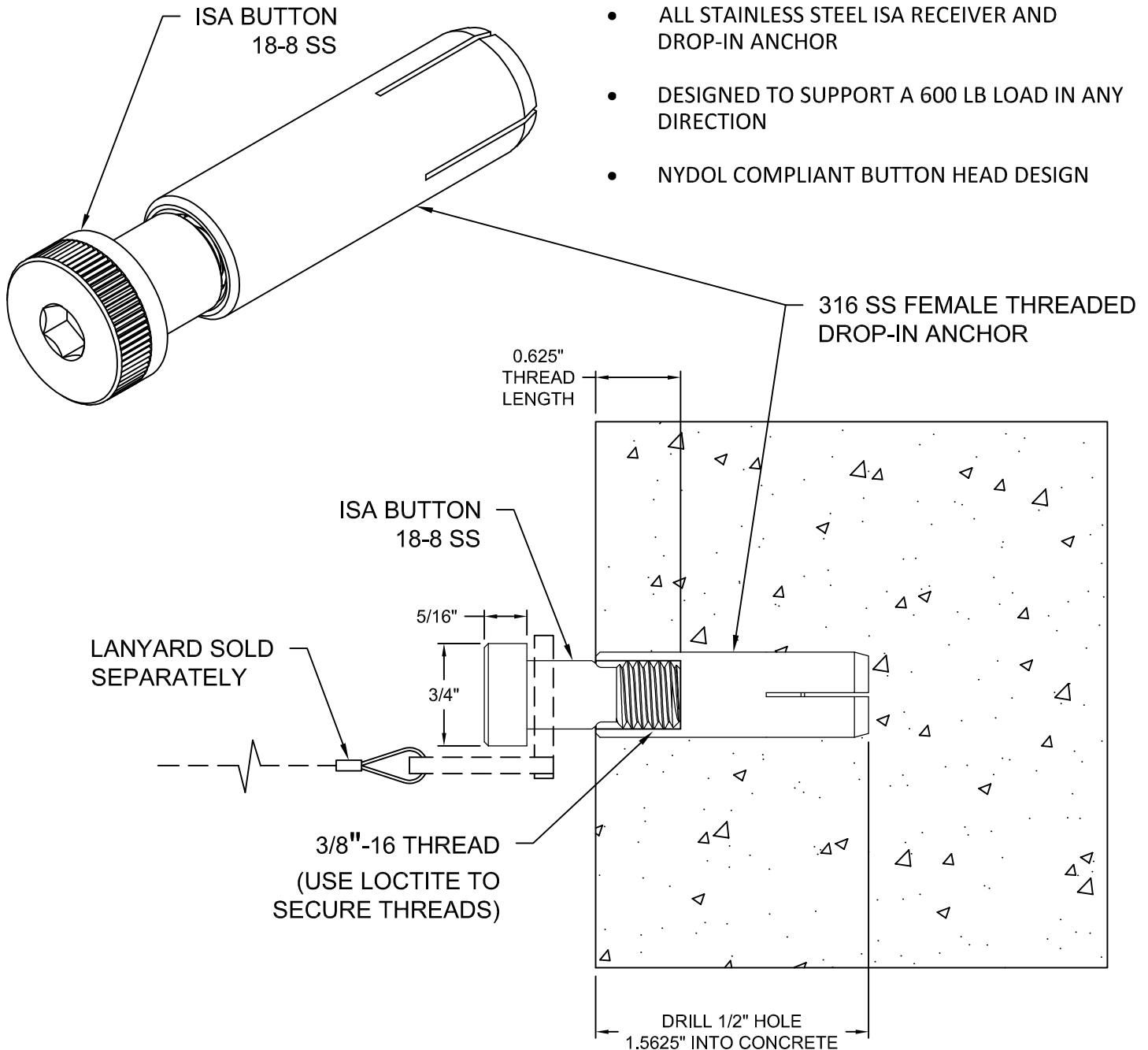

**NOTE: CUSTOMER IS RESPONSIBLE FOR THE FOLLOWING:**

- |   |  |
|---|--|
| <p>A. ENSURING THAT SKY CLIMBER'S ANCHORAGE PRODUCTS ARE ATTACHED TO AN ADEQUATE AND COMPATIBLE STRUCTURE.</p> <p>B. WHEN INSTALLED PROPERLY, SKY CLIMBER'S STANDARD ISA PRODUCTS ARE DESIGNED TO SUPPORT THE FOLLOWING LOADS:<br/>a) 600 LB ULTIMATE LOAD LIMIT (DETENT PIN WILL REMAIN ENGAGED TO ISA RECEIVER AND ISA RECEIVER WILL REMAIN ATTACHED TO THE BUILDING AT 600 LBS MINIMUM)<br/>HIGHER CAPACITY PRODUCTS ARE AVAILABLE BY REQUEST IF NEEDED.</p> <p>C. THE UNDERSTANDING THAT ANCHORS MAY FAIL DUE TO IMPROPER INSTALLATION OR INADEQUATE SUPPORTING STRUCTURE. SERIOUS INJURY OR DEATH MAY RESULT FROM ANCHOR FAILURE. INSTALLATION OF ANCHORS MUST BE PERFORMED UNDER THE SUPERVISION OF A PROFESSIONAL ENGINEER WITH EXPERIENCE IN SUSPENDED ACCESS EQUIPMENT. ADDITIONALLY, ANCHORS SHALL BE TESTED AND CERTIFIED UNDER THE SUPERVISION OF A PROFESSIONAL ENGINEER BEFORE BEING INITIALLY PLACED INTO SERVICE.</p> | <p>D. PROVIDING INFORMATION TO THE OWNER, OR THEIR REPRESENTATIVE, VERIFYING THE ANCHOR LAYOUT COMPLIES WITH APPLICABLE LOCAL AND NATIONAL CODES, REGULATIONS, AND SAFETY STANDARDS FOR THE INTENDED USE.</p> <p>E. ENSURING THAT THE APPLICATION IN WHICH THE ANCHOR(S) ARE USED AND THE STRUCTURE TO WHICH IT IS ATTACHED WILL SUPPORT THE APPLICABLE LOADS INDICATED ON THIS DRAWING. THE STRUCTURE AND FIELD CONNECTION DETAILS MUST BE FULLY DEVELOPED TO RESIST THE LOADS INDICATED ON THE DRAWINGS INCLUDING MOMENT, SHEAR, AND AXIAL FORCES. THE PROJECT ENGINEER OF RECORD IS RESPONSIBLE FOR THE DESIGN ELEMENTS OF THE CONNECTION OF THE ANCHOR TO THE STRUCTURE. THESE ELEMENTS INCLUDE, BUT ARE NOT LIMITED TO: THE INTEGRITY OF THE STRUCTURE, FIELD CONNECTION DETAILS (INCLUDING ANY FIELD WELDS OR BOLTS), ADHESIVE OR MECHANICAL ANCHOR FASTENERS, REINFORCING BARS, OR ANY OTHER ELEMENT REQUIRED IN THE CONNECTION TO SUPPORT THE ABOVE LOADS.</p> |
|---|--|