

SKY CLIMBER®

"Access Innovations Since 1955"

OPERATOR'S INSTRUCTION MANUAL

Compact 1000, 1250 & 1500 Hoists
Air & Electric Power

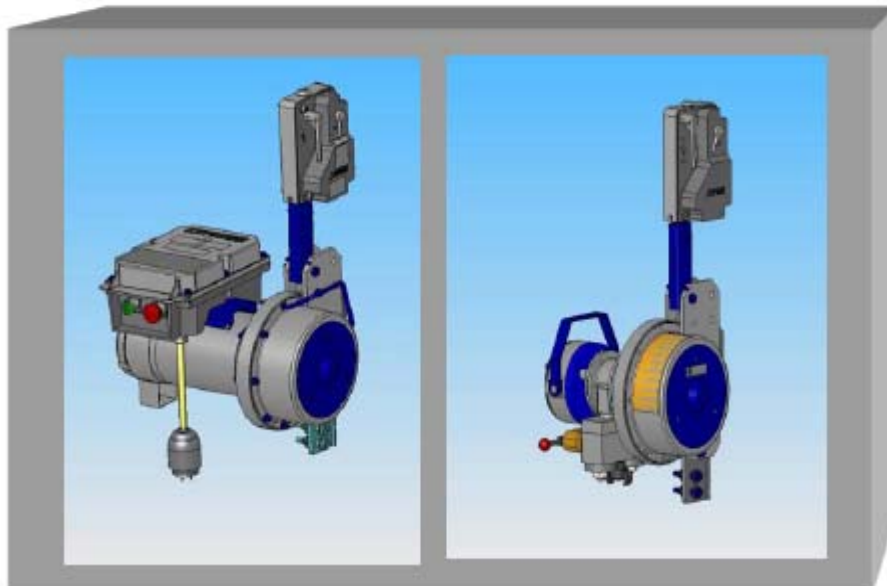

TO EMPLOYER AND/OR RENTAL AGENCY

It is imperative that this manual be given to the operator of Sky Climber equipment and that they read, fully understand, and follow all instructions contained herein.

WARNING

Any use of this equipment, other than in strict accordance with these instructions, shall be at the Operator's risk and may result in serious injury to themselves or others.

**REMEMBER SAFETY IS THE RESPONSIBILITY
OF BOTH YOU AND THE OPERATOR.**

Table of Contents

HOIST SPECIFICATIONS & CHARACTERISTICS 4

HOIST OPERATIONS 5

ELECTRICAL HOISTS 6

AIR HOISTS 6

SUSPENDED ACCESS INSTALLATION 7

 GUIDELINES 7

 TOP SIDE RIGGING 7

 SKY LOCK SECONDARY BRAKE 7

 TYPICAL TOP SIDE RIGGING SYSTEMS 8

 WIRE ROPE 9

 FALL ARREST EQUIPMENT 10

 PLATFORMS 11

 WELDING 11

 STEEL ROPE REQUIREMENTS 12

 RIGGING AND REEVING 13

HOIST & SKY LOCK INSTALLATION & TESTING 13

TROUBLESHOOTING 16

MAINTENANCE 18

SAFETY 18

 DECALS SPECIFIC TO COMPACT 1000 MODEL 19

SAFETY DECALS & INSTRUCTIONS 19

 DECALS SPECIFIC TO COMPACT 1250 MODEL 20

 DECALS SPECIFIC TO COMPACT 1500 MODEL 21

GAST AIR MOTOR - COMPACT SERIES HOISTS 22

INSPECTION FREQUENCY & MAINTENANCE 26

WIRE ROPE INSPECTION 26

CHECKLISTS 28



OPERATOR'S INSTRUCTION MANUAL

Compact 1000, 1250 & 1500 Hoists

Welcome to the ever-growing group of Sky Climber Hoist Operators. This manual will guide you through the features and the operation of your Sky Climber Hoist and Sky Lock Secondary Over-Speed Brake.

Sky Climber Hoists and Sky Lock Brakes are an integral part of a total Suspended Platform System made up of Rigging, Wire Rope, a Power Supply, the Platform, Fall Arrest/Safety Equipment and Accessories. Understanding the complete system, as well as the Hoist operation, will help you in the safe use of a Suspended Platform.

This information is a *guide only*, and is not a complete list of safety rules, installation or operation instructions.

Sky Climber Hoists, Sky Locks and Accessories are designed and manufactured to the highest standards in the industry. It is impossible, however, for Sky Climber, LLC to know, evaluate, and advise in every conceivable way our products are used or serviced and of all possible hazardous consequences.

Therefore, all Operators must satisfy themselves that the procedure they use will not jeopardize their safety, the safety of others, or cause product or component damage.

Sky Climber, LLC reserves the right to continually improve its products. Every effort has been made to make this manual as accurate as possible at the time of publication; however, there may be product changes that are not detailed in this manual.

Sky Climber LLC
1800 Pittsburgh Drive
Delaware, Ohio 43015
Telephone – 740-203-3900
Toll Free – 800-255-4629
Facsimile – 740-203-3901

HOIST SPECIFICATIONS & CHARACTERISTICS

Compact 1000, 1250 & 1500

Air & Electric Motors

ELECTRICAL SPECIFICATIONS 220v MOTORS		<u>Single Volt 1000 & 1250</u>	<u>Single Volt 1500</u>
	Power:	1.3 HP / KW 0.95	1.3 HP / KW 0.95
	Line Current:	7.5 Amps	9.24 Amps
	Power Cable:	14/3	14/3
	Voltage:	230 VAC / 60 Hz 1 PH	230 VAC / 60 Hz 1 PH
	Hoist Weight:	104 lbs.	123 lbs.
	Sky Lock III:	Included with Hoist	Included with Hoist
	Wire Rope:	5/16"	5/16"
	Ascent Speed:	32 fpm	32 fpm
	Descent Speed:	35 fpm	35 fpm
	Pendant Control:	Hoist Mounted Ctrl w/plug	Hoist Mounted Ctrl w/plug
Part #:	KCE-1000-220 KCE-1250-220	KCE-1500-220	
RPM:	1725	1725	

ELECTRICAL SPECIFICATIONS 208v MOTORS		<u>Single Volt 1000 & 1250</u>	<u>Single Volt 1500</u>
	Power:	1.2 HP / KW 0.88	1.2 HP / KW 0.88
	Line Current:	9.0 Amps	9.0 Amps
	Power Cable:	14/3	14/3
	Voltage:	208 VAC / 60 Hz 1 PH	208 VAC / 60 Hz 1 PH
	Hoist Weight:	104 lbs.	104 lbs.
	Sky Lock III:	Included with Hoist	Included with Hoist
	Wire Rope:	5/16"	5/16"
	Ascent Speed:	32 fpm	32 fpm
	Descent Speed:	35 fpm	35 fpm
	Pendant Control:	Hoist Mounted Ctrl w/plug	Hoist Mounted Ctrl w/plug
Part #:	KCE-1000-208 KCE-1250-208	KCE-1500-208	
RPM:	1685	1685	

PNEUMATIC (AIR) SPECIFICATIONS		<u>Compact 1000 & 1250 (Gast)</u>
	Power:	70 CFM
	PSI:	100
	Hoist Weight:	74 lbs.
	Ascent Speed:	35 fpm
	Descent Speed:	35 fpm
	Sky Lock III:	Included with Hoist
	Wire Rope:	5/16"
Filter & Lubricator:	Included with Hoist	
Part #:	KCA-1000-Air KCA-1250-Air	

**Detachable Sky
Lock Type III
Secondary Brake**

"No Power"
Emergency

Controlled Descent,
Meets or Exceeds
OSHA requirements

U. L. Classified

Maximum Rated
Capacity (MRC)
is total load
supported by Hoist.
It includes the
combined weights of
the stirrup, platform,
work cage, bosun
chair, personnel,
work tools or
materials, operating
accessories, power
cord, wire rope, and
hoists.

HOIST OPERATIONS

Compact 1000, 1250, 1500

ELECTRIC SINGLE VOLTAGE, DUAL VOLTAGE & AIR HOISTS WITH SKY LOCK TYPE III

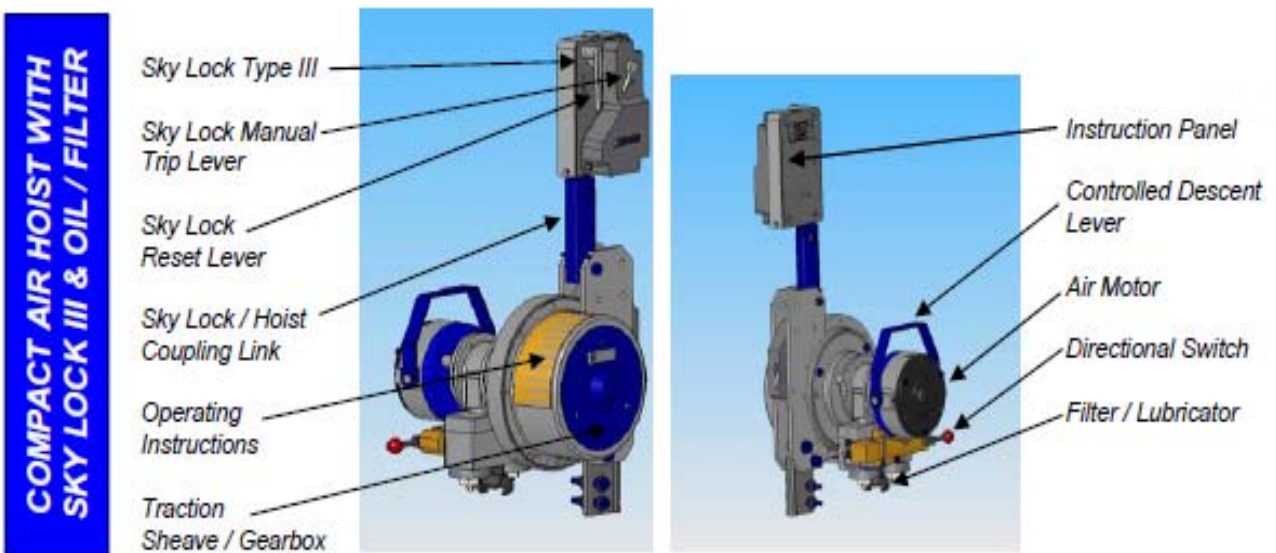
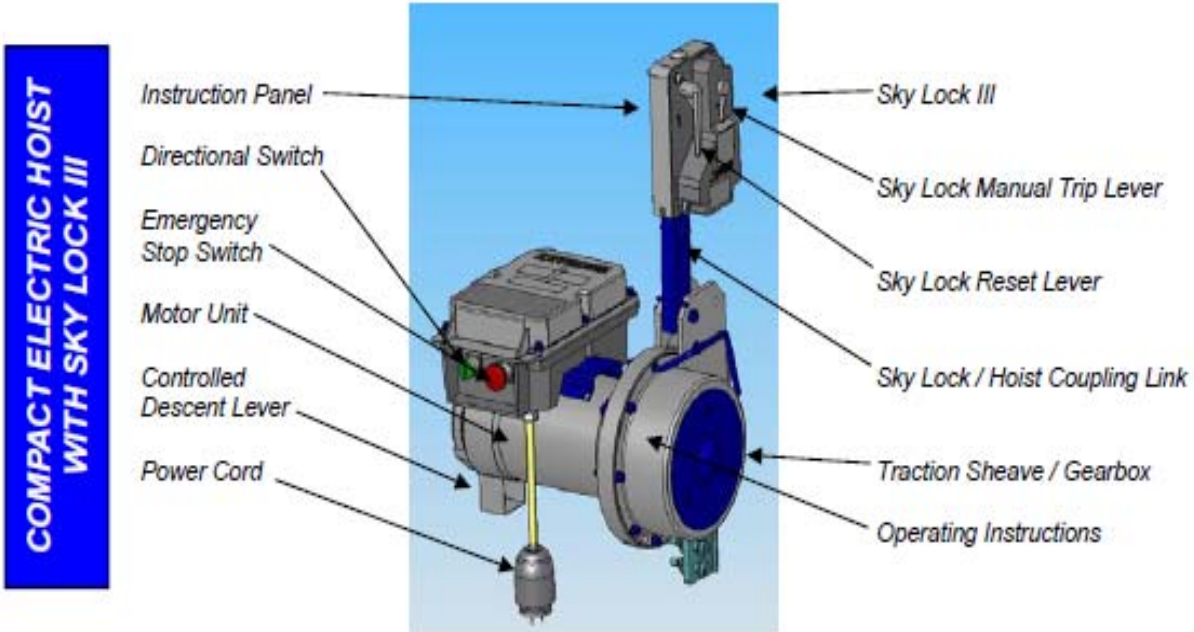

NOTICE – Select proper source voltage (208V/220V) to match hoist voltage BEFORE connecting power.

Directional Switch/Lever – This activates and operates the hoist. Select UP direction to move unit upward. Select DOWN direction to move unit downward. Release the switch to cut power to motor and set primary brake.

Emergency Stop Switch – Push to stop power to hoist and set primary brake. Turn *clockwise* to reset.

Controlled Descent Lever – Do not use for normal lowering operations. For non-powered descent, the Controlled Descent Lever manually releases and re-engages primary hoist brake. Disconnect power at power connection before using the Controlled Descent Lever.

*Dual voltage not pictured.

ELECTRICAL HOISTS



WARNING

Do not use an electric hoist in an explosive environment.

Secure cord to Platform so cord weight is on Platform and **NOT** on connection. At end of work shift, disconnect power cord from the main outlet. Protect power cords from rain and water at all times. Ground connector of building receptacle must be grounded.

- ❖ For 208/220 Volt applications, use one cord in combination with a yoke to the Hoists.
- ❖ Use a yoke off Platform line with two lengths of 10-3 SOW electric cord.
- ❖ Normally a 250 ft. 600 Volt 10-3 SOW electric cord is used.
- ❖ Use a booster transformer when low voltage is encountered.

Electrical Pendant

Part # 41021752 – (length).

AIR HOISTS

Secure hose to Platform so weight of hose is not on unit. Install two shut off valves – one at air supply source and one on Platform.

- ❖ Use a yoke off Platform line with two equal length 3/4 inch hoses.
- ❖ Hose Inner Diameter (for 100 PSI and 70 CFM / Hoist).

Hose Inner Diameter	<u>3/4"</u>	<u>1"</u>	<u>1-1/4"</u>
One Unit	400 ft.	1000 ft.	1000+ ft.
Two Units - Yoked	100 ft.	300 ft.	1000+ ft.

Filtering and Lubrication

Do not connect to air systems that use synthetic, fire-resistant lubricants – especially phosphate ester types – in the air compressor.

- ❖ An air filter and a lubricator are mounted in the input line ahead of the motor. Clean filter elements periodically.
- ❖ To service lubricator, remove oil fill plug, fill to visible rim of bowl with SAE No. 10 petroleum based hydraulic or spindle oil. Do not use oils with adhesive or tacky additives. Replace plug.
- ❖ Adjust oil flow to about 4 drops per minute. Turn slotted screw in top of lubricator *clockwise* for a leaner mix, or *counterclockwise* for a richer mix.

Air Pendant

Part # 41021753 – (length).

SUSPENDED ACCESS INSTALLATION

GUIDELINES

Safety is of the utmost importance when installing and using Suspended Platform equipment. This section covers general guidelines. Follow your Manufacturer's Instructions for proper equipment assembly. Follow all applicable Federal, State, and Local rules and regulations.

- ❖ Test your system *before* going aloft.
- ❖ Continue to check to be sure your system remains safe throughout the entire use on the job.
- ❖ Make certain there are no obstructions to the vertical platform travel.

TOP SIDE RIGGING



WARNING *Rigging is the responsibility of the user. Do not attempt to rig a job unless you are qualified. Failure of rigging will result in serious injury or death.*

- ❖ All rigging including cornice hooks, parapet clamps, and outrigger beams must be tied back to a structural member with wire rope that is equal or greater in ultimate strength than suspension line.
- ❖ Tie back must be tied tight to a substantial point that supports at least 4 times the rated Hoist load. Tie back to vent pipes is not acceptable. Tie backs must be straight back and each to a separate anchor point.
- ❖ Use parapet clamps and cornice hooks *only* on steel reinforced concrete structures. Do not use parapet clamps on non-reinforced brick, concrete block, or stone because these may fail.
- ❖ Consult a professional engineer or the building owner to verify parapet construction and strength.
- ❖ Use 3/4 inch plywood under roof rigging to spread load on roof. If parapet is used for support, use hardwood for load spread.
- ❖ Rolling Roof Rig chocks, jacks or similar devices must be securely in place to prevent any lateral movement.

SKY LOCK SECONDARY BRAKE



WARNING *A Sky Lock Secondary Over-Speed Brake safety device must be used at all times with each Sky Climber Hoist.*

Failure to do so is in violation of OSHA, and may result in serious injury or death.

The Sky Lock senses the speed of the wire rope traveling through it. If there is sudden acceleration due to a falling condition, or if the factory pre-set trip speed is exceeded, the Sky Lock Jaws clamp onto the wire rope, arrest any descent, and support the descending load. The wire rope releases *only after* the Sky Lock Brake load is relieved.

Sky Lock Manual Trip Lever – Turn lever *counterclockwise* to clamp the Sky Lock Jaws onto the wire rope.

Sky Lock Reset Lever – First use Hoist Directional Switch UP to move Hoist in an upward direction one inch to relieve the load from Sky Lock Jaws. Turn Sky Lock Reset Lever *clockwise* to reset. If you don't go up before resetting, the Sky Lock Jaws will not open, and the Sky Lock Reset Lever pin will shear. This will render the Sky Lock useless and require factory-authorized repair.

TYPICAL TOP SIDE RIGGING SYSTEMS

Counterweighted and Non-Counterweighted

- ❖ Outrigger beams require counterweights.
- ❖ Counterweights must be secured to the outrigger beam and must be of a non-flowable material.
- ❖ To calculate the needed counterweights, use the following formula:

$$\text{FORMULA: } CW = \frac{4 \times R \times L}{B}$$

CW = Counterweight (in lbs.) per outrigger beam

4 = 4:1 Safety Factor (required by OSHA)

R = Reach (Distance from Front Support center line to Hanging Load)

L = Load (Rated Working Load [RWL] of Hoist)

B= Backspan (Overall distance from fulcrum to center of counterweights)

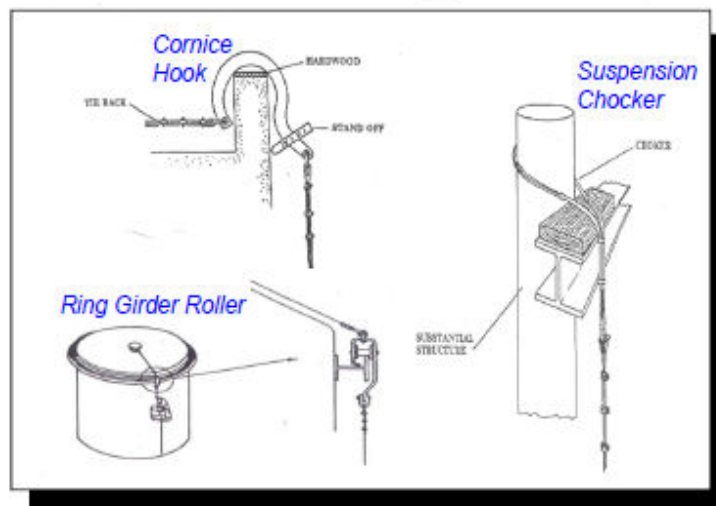
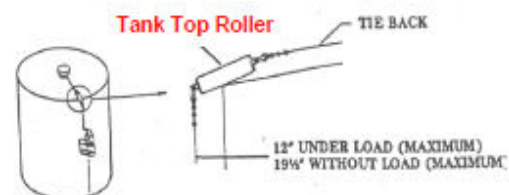
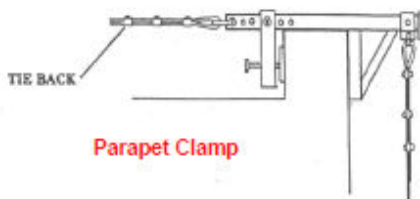
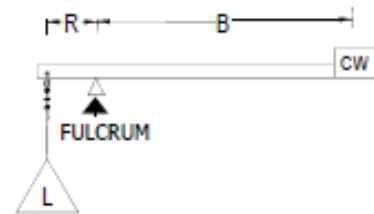

WIRE ROPE



WARNING *Wire rope is an expendable item. It begins to wear when it is put into use. Do not use kinked, bird-caged, excessively worn or damaged wire rope. Such use may result in injury or death to yourself or others.*

Wire Rope Handling and Storage

- ❖ Always wear gloves to protect your hands when working with wire rope.
- ❖ Store wire rope in a coil or on a spool.
- ❖ Protect rope from physical abuse, inclement weather, and corrosive materials.
- ❖ Do not drop wire rope from any height.
- ❖ Uncoil wire rope carefully to avoid kinking or inducing a twist.
- ❖ Do not uncoil by tossing coil over the edge of a structure.
- ❖ Avoid dragging wire rope in dirt or around objects that could scrape, crush, bend or damage it.
- ❖ Galvanized wire rope specified by Sky Climber, LLC is lubricated at the factory and under normal conditions does not require further lubrication.

Wire Rope Preparation

- ❖ Always use 5/16 inch wire rope of the proper length and construction.
- ❖ 5/16 inch, G, XIP, RL, PRF **
- ❖ Braze both ends a maximum of 1/2 inch in length.
- ❖ Air cool, then grind the tip to a blunted point.

** G = Galvanized XIP = Extra Improved Plow
 RL = Right Lay PRF = Preformed

Wire Rope Rigging

Always use correct size and type of rope clamps. Wire rope will slip through oversize clamps. Undersize clamps will damage wire rope.

- ❖ Use only 5/16 inch J-type wire rope clamps with a minimum of three clamps spaced from 2-4 inches apart.
- ❖ Do **NOT** use U-type clamps which can crush wires and reduce wire rope strength.
- ❖ Torque J-clamps to 30ft.-lb. at first loading. Check for tightness at the start of each work shift.
Clamps do loosen with use!
- ❖ After all J-clamps are placed, test for 100% proof load. Retighten clamps to specifications.
- ❖ Use a 5/16 inch thimble and a 5/8 inch shackle.
- ❖ Use insulated thimbles when welding from platform.
- ❖ Wire rope must support 6:1 safety factor.
- ❖ A properly made 5/16 inch wire rope will have a minimum breaking strength of 9,400 lbs.
- ❖ Rig from the top of structure. Allow an extra 10 feet of wire rope to reeve hoist. Store extra rope on roof neatly coiled, tied, and protected from the weather.
- ❖ Wire rope must be rigged to remain vertical with suspension points directly above the hoist entrance guide or lead-in device.
- ❖ CAUTION: If the wire rope length is less than required to LAND the platform on a safe surface, after reeving the hoist, loop the bitter end of the wire rope and secure with a J-clamp. Failure to do so may result in personal injury or death. Remove J-clamp before de-reeving hoist.

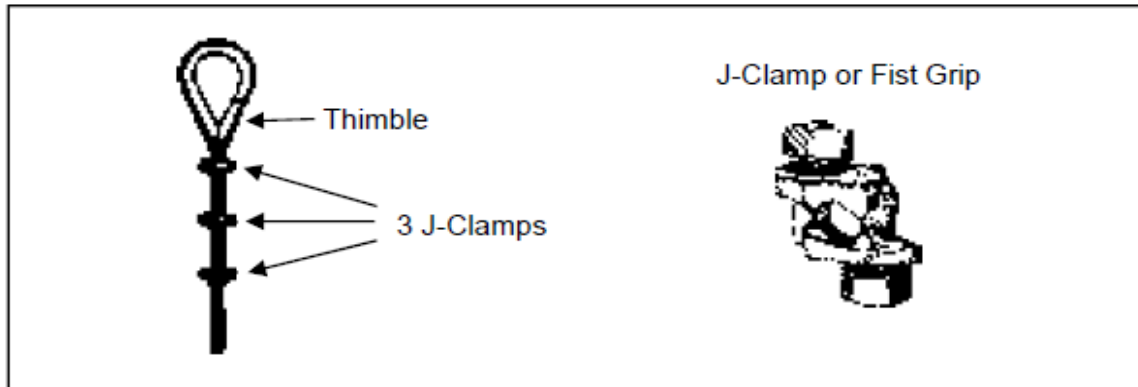

Wire Rope Replacement

- ❖ Wire rope is critical to safe and trouble-free operation.
- ❖ Replacement rope shall be to Sky Climber's specifications. Use of wire rope obtained from sources other than those specified by Sky Climber could result in serious personal injury, property damage, and/or equipment breakdown.

Four Wire System

Four wire systems can be used when it is necessary to protect workers having platforms or canopies overhead and as part of the system. Contact your Sky Climber representative when Four Wire Systems are needed.

FALL ARREST EQUIPMENT

OSHA requires an independent life line for each person going aloft. A safety harness must be worn by each worker and be attached by a lanyard and rope grab to an independent life line while a worker is on the platform.

Life Lines

Only one person may be attached to a life line. The life line must be:

- ❖ Sized for and compatible with the rope grab (e.g., 5/8 inch line for a 5/8 inch rope grab).
- ❖ Certified minimum breaking strength of 5,000 lbs.
- ❖ Seized or whipped at the ends.
- ❖ Tied off to a separate attachment point different from the wire rope attachment point capable of supporting 5,000 lbs.
- ❖ Do not allow life line to come in contact with rough or sharp edges.
- ❖ Life line must extend to the ground or the next lower safe surface.

Rope Grab

Inspect all parts of the rope grab prior to each use. Perform a documented rope grab inspection at least twice a year.

- ❖ *The rope grab should always be mounted on the life line as far above the operator as possible.*

Body Harness

Harnesses must comply with the latest edition of ANSI A10.14.

- ❖ Position a body harness D-ring in the center of the back rib cage.
- ❖ Follow the safety equipment manufacturer's instructions.

Lanyards

Lanyards must meet or exceed OSHA standards.

- ❖ Lanyards must be 4 feet long (or less with double snap locks).
- ❖ Minimum tensile strength is 5,000 lbs.

PLATFORMS

- ❖ Follow the platform load specification.
- ❖ Check stirrup bolts daily for soundness and tightness.
- ❖ Use toeboards, handrails and mid-rails on all open sides.
- ❖ Acids can destroy aluminum platforms. Replace platform immediately if exposed to acids or corrosive materials.
- ❖ Operate platform in level position only.
- ❖ Work from deck of platform only. Do not stand on guardrails, toeboards, platform/work cage supported objects or lean out from ends of the platform. Do not use ladders etc. to get at higher elevations.
- ❖ Do not bridge from one platform to another, nor to any structure or other equipment.
- ❖ Do not horizontally transfer a work platform while it is suspended in the air. Perform all transfer operations ONLY with the platform resting on a safe surface.
- ❖ Bosun chairs should carry only the operator. Do not hang loads from the seat or attach any device or support to seat or seat back.

WELDING

Use the following precautions when welding to prevent the possibility of electric shock to personnel and/or the possibility of welding current passing through the wire rope.

- ❖ Attach each wire rope to its suspension point with a suitable insulated thimble. Insulate extra rope stored on the roof to prevent grounding, or terminate the suspension rope at the insulated thimble.
- ❖ Cover the supporting wire rope with insulating material above and below the Sky Climber® Hoist. Use a length of split rubber tube taped in place around the cable as follows:
 - Extend above the Sky Lock brake for 4 to 5 feet (more if required by local codes).
 - Extend below the Sky Climber® Hoist, far enough to insulate the tail line from the platform. Guide and/or retain the portion of the tail line below the platform so that it does not become grounded.
- ❖ Cover each Sky Climber Hoist, Sky Lock Brake, and Wire Winder with protective covers made from insulating material.
- ❖ Connect a grounding conductor from the platform to the work piece. The size of this conductor must be equal to or greater than the size of the stinger lead.

NOTE: This must be a secondary conductor and must not be in series with the primary conductor between the welder and the work piece.

STEEL ROPE REQUIREMENTS

Recommended Wire Rope – Compact 1000, 1250 & 1500

Sky Climber has found the 5/16", (8.0 mm) 5-strand wire rope to be the most effective for trouble-free operation. Please use only that rope which is recommended by the manufacturer.

Product

5/16" (8.0 mm) 5 x 26 WS, PFC, G, XIP, RRL, performed, break strength at 10,500 lbs.

Compliance

Use only the specified wire rope in the Compact 1000, 1250 & 1500 Hoist. If further information is needed, please contact Sky Climber at 740-203-3900 or 800-255-4629. All wire rope used must conform to Federal Specifications RR-W-410P Type 1, General Purpose, Class 2. The supplier should provide a Certification of Breaking Strength proving a minimum strength. The wire rope **MUST** have a breaking strength at least six (6) times the rated load of the hoist (6:1 Design Safety Factor). This rope is resistant to abrasion and crushing with medium fatigue resistance.

WS	Warrington Seal	PFC	Polypropylene Fiber Core
G	Galvanized	XIP	Extra Improved Plow
RRL	Regular Right Lay Steel		

Tiping and Braising

Braze a wire rope tip by applying braze to approximately 1/2 inch of tip (do not exceed 3/4 inch) and let it glow to all of the individual wires. Let the rope **AIR COOL**. Air cooling is very important. Then grind the tip to a taper, but not a point. Tip should resemble a pencil with the lead broken off.



How to Check for Proper Wrapping

Cut 50 to 100 feet from your new spool of specified wire rope. Braze both ends and run it through a hoist 10 times (no load needed). Check if the strands are separating above or below the hoist. If they **DO** appear to be opening, then the strands are improperly wrapped and will result in hoist jamming. Return the spool to your supplier.

Quality

Wire rope must be of good quality and free of damage or defects (see Wire Rope Inspection in this manual). The wire rope must be inspected every day by a competent person.

RIGGING AND REEVING

At the job site, rig from the top down. Lower wire rope until you have about 10 feet of rope on the ground (hoist is not yet reeved). Complete the tie point with 3 fist grips (or J-clamps), thimble and shackle (torque fist grips to manufacturer's recommendations). Store the extra wire rope in a coil on the roof.

NOTE: Adjust wire rope length as you change elevations. Reeve the hoist, form a 360° loop in the tail end and retain with a fist grip. Before dereeving the hoist, remove the fist grip.

HOIST & SKY LOCK INSTALLATION & TESTING

Suspended Platform Assembly

- ❖ Follow manufacturer's instructions.
- ❖ If used, install an electric yoke on the platform (wrapped around center guardrails) to provide power to each hoist.
- ❖ Secure source power line(s) to Suspended Platform by strain relief(s) or other load-bearing device. Plug the power line into yoke (if used).
- ❖ Allow sufficient power line length to permit free platform travel without undue strain to the power line and platform.

Sky Lock Installation

- ❖ Insert the end of hanging wire rope through Sky Lock.
 - Move Sky Lock up rope to a location above hoist attachment point.
- ❖ Test Sky Lock.
 - Support Sky Lock vertically. Drop Sky Lock down the wire rope.
 - Brake should lock onto rope within 3 inches or less.
 - Slide Sky Lock up wire rope 1 inch.
 - Turn Reset Handle *clockwise* to reset Sky Lock.
 - Repeat procedure **twice**. Leave Sky Lock on line for hoist reeving.
 - Sky Lock **must** lock onto rope within 3 inches or less. If it does not, Sky Lock **must** be replaced.
- ❖ After test, proceed with hoist installation.

Hoist Installation

- ❖ Place hoist next to Suspended Platform Stirrup.
- ❖ Connect Power.
 - On dual voltage hoists (110 or 220), set voltage selector switch to source voltage BEFORE connecting power. Then connect power.
- ❖ Thread wire rope through hoist.
- ❖ **Keep hands clear of pinch point where wire rope enters hoist.**
 - Feed brazed and pointed end of wire rope with Sky Lock Brake already hanging on the rope into hoist entrance guide until rope stops.
 - To start self-reeving, move Directional Switch to UP direction.
 - Wire rope must be free to travel without interference.

- Exit guide must be clear. Wire rope must run freely **away** from the hoist.
- Guide hoist as it climbs up to the stirrup level.
- ❖ Attach hoist to Suspended Platform Stirrup.
 - Insert hoist stirrup strap into platform stirrup recess.
 - Use either Grade 5 nuts/bolts or shoulder bolts and nuts provided by manufacturer.
 - Tighten nuts securely.
 - Make sure wire rope exits outward, away from platform's work area.
- ❖ Assemble Sky Lock Hoist with Coupling Link.

Coupling Link must provide clearance for straight passage of wire rope.

 - Remove Coupling Link from storage box.
 - Line up Coupling Link with hole in the top of Hoist.
 - Attach with shoulder bolt. Tighten nut securely.
 - Slide Sky Lock up one inch, then turn Sky Lock Reset Lever *clockwise* to open jaws, letting Sky Lock slide down wire rope.
 - Line up hole in Sky Lock with the top of the Coupling Link.
 - Attach shoulder bolt. Tighten nut securely.
- ❖ Secure Wire Rope End.
 - Limit wire rope bitter end to a few feet. Store excess wire rope at top on suspension end.



WARNING

Serious injury or property damage may result from falling objects during hoist load test. Be alert and prepared to quickly move from the likely impact zone.

- ❖ Test Hoist Load.
 - Place load equal to weight of workers, tools and materials on one end of the platform. Have co-worker check rigging for slippage/malfunction during the test.
 - Inspect all rigging/platform connections. Tighten or adjust as needed.
 - Select Hoist Directional Switch UP direction to raise the platform **6 inches** off surface.
 - Turn Manual Trip Lever *counterclockwise* to set the Sky Lock Brake.
 - Select Hoist Directional Switch DOWN direction. **System should not descend.** Wire rope will loop out between the top of the hoist and the bottom of the Sky Lock.
 - Select Hoist Directional Switch in the UP direction to take up the loop and raise the platform **one inch** to relieve the load from Sky Lock Jaws.
 - Turn Sky Lock Reset Handle *clockwise* to reset Sky Lock.
 - Repeat procedure twice.
 - Repeat the same hoist load test procedure at the other end of the platform.
 - If hoist or Sky Lock fails test, return failed unit to Factory Authorized Service Center.
- ❖ Test Emergency Stop Button.
 - Select Hoist Directional Switch in the UP direction to raise platform **6 inches**. While ascending, press the Emergency Stop Button. Power should stop to hoist and primary brake should engage.
 - Turn Emergency Stop Button Switch *clockwise* to reset.
 - Repeat test.
 - If Emergency Stop fails, return hoist to Factory Authorized Service Center.

❖ Test Controlled Descent System.

Partial Hoist Brake Release may result in overheating and premature wear.

- Raise suspended equipment **2 feet** off the ground.
- Use the Controlled Descent Lever to manually release the primary hoist brake.

NOTE: Whenever using the non-powered controlled descent feature, the hoist's **E-stop** MUST be actuated and the power to the hoist disconnected prior to descending.

- For non-powered descent, pull the Controlled Descent Lever as far as it will go toward the end of the motor.
- The hoist should lower at about 35 feet per minute.

Do NOT use any equipment that has failed testing!

TROUBLESHOOTING

Mechanical portions of Sky Climber Hoists and Sky Lock must **not** be repaired in the field. Perform only those repairs for which you are qualified and trained. If a problem condition still exists, contact your Sky Climber representative.

<u>PROBLEM</u>	<u>POSSIBLE CAUSE</u>	<u>CORRECTIVE ACTION HOIST</u>
Hoist won't come down	Sky Lock Brake tripped	Over speed Condition: Get off platform! Nuisance Tripping: Run system up 1" Reset
Electric Motor runs slow or hums and will not lift	Low source voltage	Use booster transformer or separate drop cords
	On long drops, too much voltage is lost in electric cord.	Use booster transformer or separate electric cord to each unit
	Badly "pitted" points Brake not releasing Defective contactor Capacitor	Return to Factory Authorized Service Center
Motor Overheats	Incorrect Voltage	Motors overheat at less than 200V or greater than 240V for 220V motors and less than 190V and greater than 220V for 208V motors
"Popping" Circuit Breaker	Breaker undersized	Connect to proper size breaker
	Short in electric cord	Replace cord
Runs in only one direction	Defective contactor center	Return to Factory Authorized Service Center
Motor does nothing	No Power	Restore
	Thermal protector tripped (motor is usually hot)	After one hour cooling period, restart
	Emergency Stop Switch engaged	Disengage
Hoist drifts when stopping is in DOWN direction	Primary brake worn	Return to Factory Authorized Service Center

SKY LOCK

Remove personnel from platform.
Lower platform to ground or raise to roof by means other than the hoist.
Contact Sky Climber representative.
DO NOT release or reset brake.

TROUBLESHOOTING (Continued)

POSSIBLE PROBLEMS WITH AIR MOTOR					
Low Torque	Low Speed	Won't Run	Runs Hot	Runs Well Then Slows Down	REASON & REMEDY FOR PROBLEM
❖	❖	❖			Dirt or foreign material present. Inspect and flush.
❖	❖	❖			Internal rust. Inspect and flush.
❖	❖				Low air pressure. Increase air pressure.
	❖				Air line too small. Install larger line(s).
	❖			❖	Restricted exhaust. Inspect and repair.
❖	❖	❖		❖	Motor is jammed. Have motor serviced.
	❖			❖	Air source inadequate. Inspect and repair.
	❖			❖	Air source too far from motor. Reconfigure setup.

MAINTENANCE

Return Sky Climber Hoists as indicated to Factory Authorized Service Center for maintenance.

- ❖ Sky Climber Hoists are lubricated for normal usage and life. If an oil leak is seen, return hoist to Factory Authorized Service Center.
- ❖ Keep rope housing drain holes at bottom of hoist open.

FLUSHING: Keep Hoist and Sky Lock free of contaminants. Perform the following steps when using equipment in a contaminated environment using gunite, hydroblasting, or sand-blasting:

- ❖ Lower equipment to ground. De-reeve the hoist.
- ❖ Hold hose at wire rope entrance, flush Sky Lock with fresh water.
- ❖ Repeat flushing on the Hoist while running hoist in the UP and DOWN direction until no further contaminants exit from drain holes.
- ❖ Reeve the hoist and Sky Lock. Continue operations.

SAFETY

Accidents will be prevented if you follow the instructions in this manual. Once the equipment leaves Sky Climber's control, the Operator is responsible for the safe use, operation, and maintenance.

Safety Prevents Accidents

- ❖ Know and understand the operation of this equipment.
- ❖ All Federal, State, and local codes and regulations that apply to this equipment and its safe use **must** be followed.
- ❖ Do **not** alter any Sky Climber Hoists, Sky Locks or Accessories. Use **only** Sky Climber original parts in your Sky Climber equipment.
- ❖ Thoroughly inspect **all** equipment **before** use. Do **not** use any equipment that has any apparent difficulty.
- ❖ **Wear hard hats** at all times when servicing, erecting, disassembling, or using equipment.
- ❖ Secure suspended platform to building face/structure while at workstation. Disconnect platform from building face (other than platforms using continuous engagement) **before** it is moved.
- ❖ Provide protection for workers from falling objects both **above** and **below** the equipment.
- ❖ Keep all persons from **beneath** suspended equipment.
- ❖ **Never** work alone on a suspended platform, and ensure help is available in an emergency.
- ❖ Do **not** overload the equipment or exceed the maximum rated capacity as noted in this manual.
- ❖ Do **not** wear loose clothing while operating this equipment.

SAFETY IS IMPORTANT.

Use Common Sense ... Do NOT Take Chances!

SAFETY DECALS & INSTRUCTIONS

DECALS SPECIFIC TO COMPACT 1000 MODEL

DECAL Part No. 600-100 (220v)
600-118 (208v)



DECAL Part No. 600-102



DECAL Part No. 305-388

DECAL Part No. 800-109

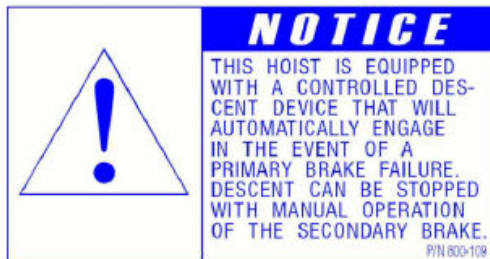

DECAL Part No. 600-101
or 600-101 (B)



DECAL Part No. 305-398

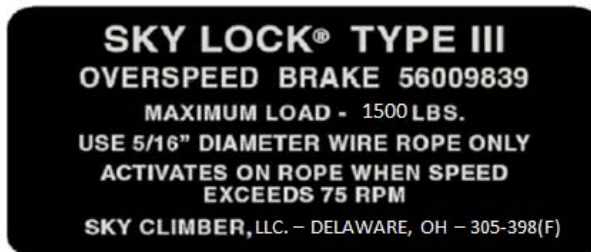

DECAL Part No. 102-242
For electric motor only

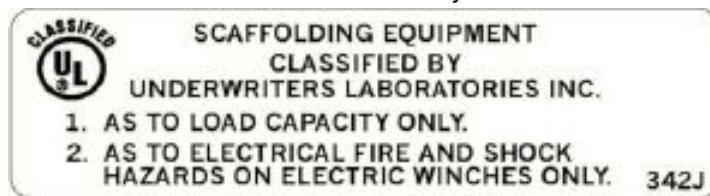

DECAL Part No. 56008971



DECAL Part No. 102-379
For air motor only

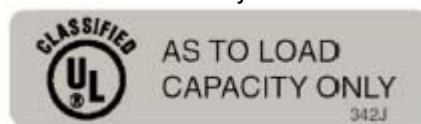

DECAL Part No. 12009202



DECAL Part No. 305-394



DECALS SPECIFIC TO COMPACT 1250 MODEL

DECAL Part No. 600-95 (220v)
600-119 (208v)



DECAL Part No. 600-97



DECAL Part No. 600-97

DECAL Part No. 800-109

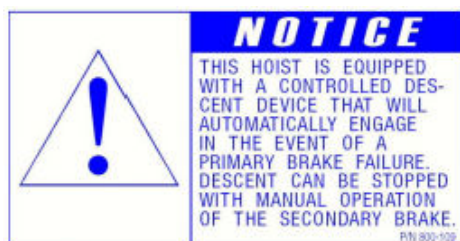

DECAL Part No. 600-101

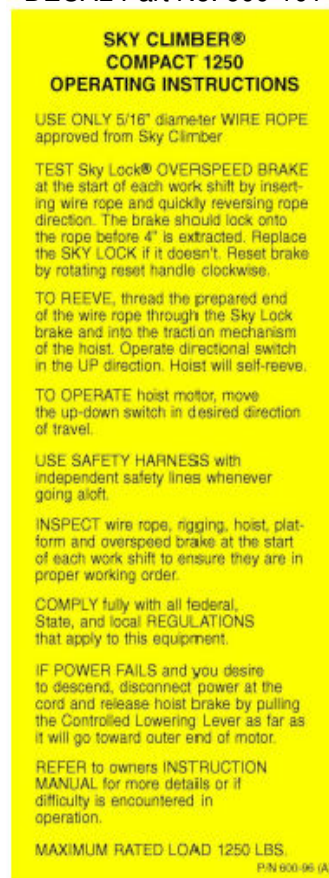

DECAL Part No. 56008971



DECAL Part No. 305-404

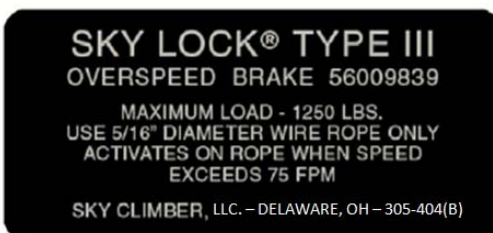

DECAL Part No. 102-242

Electric Hoist only

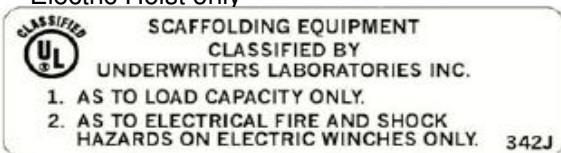

DECAL Part No. 305-394



DECAL Part No. 12009202

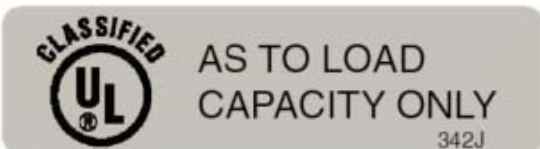

DECAL Part No. 102-379
For air motor only

DECALS SPECIFIC TO COMPACT 1500 MODEL

DECAL Part No. 600-15

SKY CLIMBER
"Access Innovations Since 1955"

230 VAC 60 Hz 1 PHASE 1.3 HP 9.3 AMP 30 MIN. DUTY 600-15 (B)	COMPACT 1500 MADE IN USA WORLD WIDE DISTRIBUTION	DELAWARE, OHIO 5/16 INCH DIA. WIRE ROPE MAX. RATED LOAD 1500 LBS.
--	---	--

DECAL Part No. 305-394

305-394-P



**STOPS OVERSPEED
ROPE TRAVEL THRU
PRO LOCK IN
ARROW DIRECTION**

DECAL Part No. 800-109



NOTICE

THIS HOIST IS EQUIPPED WITH A CONTROLLED DESCENT DEVICE THAT WILL AUTOMATICALLY ENGAGE IN THE EVENT OF A PRIMARY BRAKE FAILURE. DESCENT CAN BE STOPPED WITH MANUAL OPERATION OF THE SECONDARY BRAKE.

P/N 800-109

DECAL Part No. 12009202

➔

MANUAL TRIP

P/N 12009202

DECAL Part No. 600-112

SKY CLIMBER®
COMPACT 1500
OPERATING INSTRUCTIONS

USE ONLY 5/16" diameter WIRE ROPE approved from Sky Climber

TEST Sky Lock® OVERSPEED BRAKE at the start of each work shift by inserting wire rope and quickly reversing rope direction. The brake should lock onto the rope before 4' is extracted. Replace the SKY LOCK if it doesn't. Reset brake by rotating reset handle clockwise.

TO REEVE, thread the prepared end of the wire rope through the Sky Lock brake and into the traction mechanism of the hoist. Operate directional switch in the UP direction. Hoist will self-reeve.

TO OPERATE hoist motor, move the up-down switch in desired direction of travel.

USE SAFETY HARNESS with independent safety lines whenever going aloft.

INSPECT wire rope, rigging, hoist, platform and overspeed brake at the start of each work shift to ensure they are in proper working order.

COMPLY fully with all federal, State, and local REGULATIONS that apply to this equipment.

IF POWER FAILS and you desire to descend, disconnect power at the cord and release hoist brake by pulling the Controlled Lowering Lever as far as it will go toward outer end of motor.

REFER to owners INSTRUCTION MANUAL for more details or if difficulty is encountered in operation.

MAXIMUM RATED LOAD 1500 LBS.

DECAL Part No. 102-242

For electric motor only



**SCAFFOLDING EQUIPMENT
CLASSIFIED BY
UNDERWRITERS LABORATORIES INC.**

1. AS TO LOAD CAPACITY ONLY.
2. AS TO ELECTRICAL FIRE AND SHOCK HAZARDS ON ELECTRIC WINCHES ONLY.

342J

DECAL Part No. 56009871

TYPE III

5/16

P/N 56009871

DECAL Part No. 305-405

SKY LOCK® TYPE III
OVERSPEED BRAKE 56009839

MAXIMUM LOAD - 1500 LBS.
USE 5/16" DIAMETER WIRE ROPE ONLY
ACTIVATES ON ROPE WHEN SPEED
EXCEEDS 75 FPM

SKY CLIMBER, LLC. - DELAWARE, OH - 305-405(B)

DECAL Part No. 600-97

CAUTION



1. Should the Sky Lock engage due to an overspeed condition, do not release or reset until load has been lowered or tied off on alternative supporting rope. Return Sky Lock to Sky Climber for inspection prior to further use.

2. Sky Lock may also be engaged by:
 a) Turning manual trip handle counterclockwise.
 b) Sudden movement of rope on platform or repeated vibration.

In the event Sky Lock engages for reason other than overspeed, check condition of equipment and wire rope before Sky Lock; if satisfactory, operate hoist in UP direction 3 inches to release load on Sky Lock, then turn reset handle clockwise until Sky Lock resets. After resetting, handle must return to vertical position.

3. Inspect and functionally check Sky Lock operation daily when used in normal environments and every 4 hours when used in contaminating environments per instructions contained in manual. Failure to regularly check Sky Lock may result in loss of function with potential injury to user.

305-088

DECAL Part No. 102-242

For air motor only



**AS TO LOAD
CAPACITY ONLY**

342J

GAST AIR MOTOR - COMPACT SERIES HOISTS



PART NO. C1-30710 (Rev. A)
 Sky Climber LLC.
 1800 Pittsburgh Dr.
 Delaware, OH 43015
 740-203-3900
 1-800-255-4629
 www.skyclimber.com

LUBRICATED AIR MOTOR MODEL # 42008201 OPERATION & MAINTENANCE MANUAL



Thank you for purchasing this Gast product. It is manufactured using quality materials. This manual includes general safety instructions for operation under normal conditions and for operation in hazardous conditions. Please follow all recommended maintenance, operational and safety instructions and you will receive years of trouble free service.

WARNING

PLEASE READ THIS MANUAL COMPLETELY BEFORE INSTALLING AND USING THIS MOTOR. SAVE THIS MANUAL FOR FUTURE REFERENCE AND KEEP IN THE VICINITY OF THE MOTOR.

General information

Operating Pressure Limits:	Gast/Sky Climber Model # 6AM-NRV-67 / 42008201	Pressure 100 PSI / 7 bar
----------------------------	---	-----------------------------

Clearances: 0.0035/0.0889 Total End Clearance in./mm 0.0015/0.0381 Top Clearance in./mm

Vane Life: Depends upon speed, operating pressure and motor maintenance. In normal operating conditions inspect vanes after 5,000 to 8,000 hours of operation.

Product Use Criteria:

- Normal conditions: Operate at temperatures up to 250°F (121°C).
- Hazardous conditions: Operate at temperatures up to 104°F (40°C).
- Protect unit from dirt and moisture.
- Use ONLY compressed air to drive motor.
- Air lines connected to motor should be the same size or the next size larger than the inlet port for efficient output and speed control.
- Protect all surrounding items from exhaust air.
- Bearings are grease packed.
- Use Gast #AD220 or a detergent SAE10 automotive engine oil for lubricating.
- Motors are to be used in commercial installations only.
- This symbol appears on labels of air motors that are designed for use in hazardous atmospheres. These air motors comply with the applicable standards and specifications and meet the requirements of the guidelines of the EC directive zones 1 and 2 where explosive atmospheres are likely to occur.
- Air supply, directional control valve and pressure regulator should be selected based upon the air consumption of the motor.



ISO 9001 & 14001 CERTIFIED

www.gastmfg.com

©Registered Trademark™ Trademark of Gast Manufacturing Inc., Copyright © 2003 Gast Manufacturing Inc. All Rights Reserved

Your safety and the safety of others is extremely important.

We have provided many important safety messages in this manual and on your product. Always read and obey all safety messages.

 This is the safety alert symbol. This symbol alerts you to hazards that can kill or hurt you and others. The safety alert symbol and the words "DANGER" and "WARNING" will precede all safety messages. These words mean:

 **DANGER**





You will be killed or seriously injured if you don't follow instructions.

 **WARNING**

You can be killed or seriously injured if you don't follow instructions.

All safety messages will identify the hazard, tell you how to reduce the chance of injury, and tell you what can happen if the safety instructions are not followed.

CODE SYMBOLS

-  Hazard. Possible consequences: death or severe injuries.
-  Hazardous situation. Possible consequences: slight or mild injuries.
-  Dangerous situation. Possible consequences: damage to the drive or the environment.
-  Important instructions on protection against explosion.
-  Application tips and useful information.

Improper environment, installation and operation can result in severe personal injury and/or damage to property.

Qualified personnel must perform all work to assemble, install, operate, maintain and repair air motor.

- Qualified personnel must follow:
- These instructions and the warning and information labels on the motor.
 - All other drive configuration documents, startup instructions and circuit diagrams.
 - The system specific legal regulations and requirements.
 - All current applicable national and regional publications regarding explosion protection, safety and accident prevention.

 Complete the following checklist prior to starting installation in a hazardous area. All actions must be completed in accordance with ATEX 100a.

Checklist for installation in hazardous areas:

- Read air motor label to check that motor has been designed for use in a hazardous application:
 - Hazardous zone
 - Hazardous category
 - Equipment group
 - Temperature class
 - Maximum surface temperatures

Example:
 Model designation: 6AM-NRV-67
 Year manufactured: 2006
 Gast Mfg. Corp.
 II 2GD c T5*
 Benton Harbor, MI USA
 ephone: 269.926.6171



- *Legend:
- II Equipment group II
 - 2 Equipment category 2
 - G Gas atmospheres
 - D Dust atmospheres
 - c Constructional safety
 - T5 Max. surface temp. 212°F/100°C

- Check the site environment for potentially explosive oils, acids, gases, vapors or radiation.
- Check the ambient temperature of the site and the ability to maintain proper ambient temperature.
 Ambient range:
 Normal conditions: 34°F/1°C to 250°F/121°C
 Hazardous conditions: 34°F/1°C to 104°F/40°C
- Check the site to make sure that the air motor will be adequately ventilated and that there is no external heat input (e.g. couplings). The cooling air may not exceed 104°F/40°C.
- Check that products to be driven by the air motor meet ATEX approval.
- Check that the air motor is not damaged.

INSTALLATION

Correct installation is your responsibility. Make sure you have the proper installation conditions.

  **WARNING**

 **Injury Hazard** 

Install proper guards around output shaft as needed. Air stream from product may contain solid or liquid materials that can result in eye or skin damage. Wear eye protection when installing this product. Failure to follow these instructions can result in serious injury or property damage.

Mounting

This product can be installed in any orientation. Mount the motor to a solid metal base plate that is mounted to a stable, rigid operating surface. Use shock mounts to reduce noise and vibration. Install a pressure regulator or simple shut-off valve to control motor.

Connection

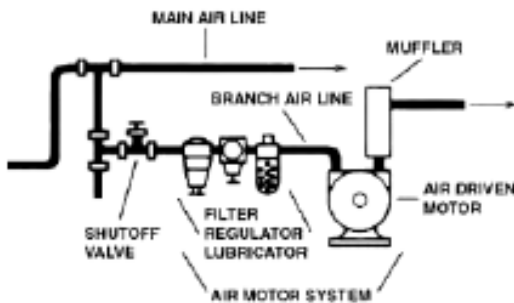

Check the direction of the motor airflow. A single rotation motor will operate properly only in one direction. Single rotation motors require a sound absorber to be connected to the air port. Remove the plastic shipping plugs from the ports. Save plugs for future use during shutdown.

Install a 5-micron filter in the air line before the connection to the motor. Next install an air pressure regulator to control motor speed and torque.

An automatic air line lubricator should be installed in the air line as close as possible and no more than 18 inches (1/2 meter) from the air motor. Install the lubricator level with or above the air motor so that the oil mist will blow directly into or fall down into the motor.

Fill the oil reservoir to the proper level with Gast #AD220 or SAE 10W high detergent motor oil. For food processing applications, White Rex 425 food grade motor oil is FDA approved. Adjust lubricator to feed 1 drop of oil for every 50 CFM of air while the unit is running, or 1 drop of oil per continuous minute of run time. Do not overfeed oil or exhaust air may become contaminated.

Clean the compressed air connection with low pressure air to remove any dirt from the line before connecting to the ports.

Use the proper sized fasteners. For the most efficient output and control of speed, use air lines that are the same size as the motor inlet port if the connection is less than 7 feet (2 meters). For longer connections, use the next pipe size larger than the motor intake port. Connect lines to motor in the proper direction.

A reversible motor will work equally well in both directions. Connect a 4-way valve with piping to both air ports of motor to make reversing possible. Connect the sound absorber on the exhaust air port or valve connection.

Do not add any thrust to the end or side of the shaft when making connections.

Ex Do not use a hammer on the shaft or connections.

STOP Lubricating the drive shaft will make assembly easier. Use a puller for removal of pulleys, couplings and pinions on the motor shaft. Check that the tension on the belt pulley matches the manufacturer's specifications. Do not exceed the maximum radial and axial forces on the shaft. If the motor shaft is connected to the part to be driven without a coupling, check that the radial offset and axial force effect will not cause problems.

Ex Use only belts with <math><10^9</math> electrical leakage resistance to prevent static electrical problems. Ground the motor.

Accessories

Consult your Gast Distributor/Representative for additional filter recommendations. Install a moisture trap and 5 micron filter in the air line ahead of motor.

Air consumption data at various speeds and pressures are available from your Gast Distributor/Representative or the factory.

OPERATION

WARNING		
Injury Hazard		
Air stream from product may contain solid or liquid material that can result in eye or skin damage. Do not use combustible gases to drive this motor. Wear hearing protection. Sound level from motor may exceed 85 db(A). Failure to follow these instructions can result in eye injury or other serious injury.		

Check all connections before starting motor. It is your responsibility to operate this product at recommended speeds, loads and room ambient temperatures. **Do not run the motor at high speeds with no load.** This will result in excessive internal heat that may cause motor damage.

The starting torque is less than the running torque. The starting torque will vary depending upon the position of the vanes when stopped in relation to the air intake port.

Use a pressure regulator and/or simple shut-off valve to regulate the motor's speed and torque. This will provide the required power and will conserve air. Open the air supply valve to the motor. Set the pressure or flow rate to the required speed or torque. Adjust the lubricator to feed one drop of oil for every 50-75 CFM (1.5-2 M³ per minute) of air moving through the motor. Check the oil level daily.

Operate the motor for approximately 2 hours at the maximum desired load. Measure the surface temperature of the motor on the casting opposite the pipe ports. The maximum surface temperature listed on the motor is for normal environmental and installation conditions. For most air motors, the maximum surface temperature should not exceed 203°F/95°C. Do not continue to operate the motor if the measured surface temperature exceeds temperature listed on the motor. If your measured temperature does exceed listed value, consult with your Gast Distributor/Representative for a recommendation.

MAINTENANCE	
	WARNING
Injury Hazard	
Disconnect air supply and vent all air lines. Wear eye protection when flushing this product. Air stream from product may contain solid or liquid material that can result in eye or skin damage. Flush this product in a well ventilated area. Do not use kerosene or other combustible solvents to flush this product. Failure to follow these instructions can result in eye injury or other serious injury.	

It is your responsibility to regularly inspect and make necessary repairs to this product in order to maintain proper operation.

Lubrication

Use Gast #AD220 or a detergent SAE #10 automotive engine oil for lubricating. Lubricating is necessary to prevent rust on all moving parts. Excessive moisture in air line may cause rust or ice to form in the muffler when air expands as it passes through the motor. Install a moisture separator in the air line and an after cooler between compressor and air receiver to help prevent moisture problems.

Manual Lubrication

Shut the air motor down and oil after every 8 hours of operation. Add 10-20 drops of oil to the air motor intake port.

Automatic Lubrication

Adjust inline oiler to feed 1 drop of oil per minute for high speed or continuous duty usage. Do not overfeed oil or exhaust air may become contaminated.

Check intake and exhaust filters after first 500 hours of operation. Clean filters and determine how frequently filters should be checked during future operation. This one procedure will help assure the motor's performance and service life.

Flushing

Flushing this product to remove excessive dirt, foreign particles, moisture or oil that occurs in the operating environment will help to maintain proper vane performance. Flush the motor if it is operating slowly or inefficiently.

Use only Gast #AH255B Flushing Solvent. DO NOT use kerosene or ANY other combustible solvents to flush this product.

1. Disconnect air line and muffler.
2. Add flushing solvent directly into motor. If using liquid solvent, pour several tablespoons directly into the intake port. If using Gast #AH255B, spray solvent for 5-10 seconds into intake port.
3. Rotate the shaft by hand in both directions for a few minutes.
4. You must wear eye protection for this step. Cover exhaust with a cloth and reconnect the air line.
5. Restart the motor at a low pressure of approximately 10 PSI / 0.7 bar until there is no trace of solvent in the exhaust air.
6. Listen for changes in the sound of the motor. If motor sounds smooth, you are finished. If motor does not sound like it is running smoothly, installing a service kit will be required (See "Service Kit Installation").



Check that all external accessories such as relief valves or gauges are attached and are not damaged before operating product.

Cleaning sound absorber

1. Remove the sound absorber.
2. Clean the felt filter.
3. You must wear eye protection for this step. Lubricate motor with 3-4 drops of oil.
4. Check the air compressor.
5. Listen for changes in the sound of the motor. If motor sounds smooth, you are finished. If motor does not sound like it is running smoothly, installing a service kit will be required (See "Service Kit Installation").

Shutdown

It is your responsibility to follow proper shutdown procedures to prevent product damage.

1. Turn off air intake supply.
2. Disconnect air supply and vent all air lines.
3. Disconnect air lines.
4. Remove air motor from connecting machinery.
5. Remove the muffler.
6.   **Wear eye protection. Keep away from air stream.** Use clean, dry air to remove condensation from the inlet port of the motor.
7. Lubricate motor with a small amount of oil into the intake port. Rotate shaft by hand several times to distribute oil.
8. Plug or cap each port.
9. Coat output shaft with oil or grease.
10. Store motor in a dry environment.



Disposal (Please note current regulations)

Parts of the air motor or air powered gear motor, shafts, cast iron or aluminum castings, gear wheels as well as rolling contact bearings may be recycled as scrap metal.

INSPECTION FREQUENCY & MAINTENANCE



WARNING

Failure to comply with Periodic Inspection and Factory Authorized Service Maintenance may result in a malfunction and/or in serious personal injury, property damage, or death.

Field Inspection

Inspection **must** be performed by a designated qualified person or operator.

Inspection Frequency

Inspect **ALL** equipment as follows:

- ❖ When the system is reeved.
- ❖ At the start of each work shift.
- ❖ At least every 4 hours in abrasive, caustic, or adhesive conditions.
- ❖ At least every 2 hours in freezing conditions.

Factory Inspection, Maintenance, and Testing

Return Sky Climber Hoists and Sky Lock Brakes to a Factory Authorized Service Center for inspection, maintenance, and testing as follows:

- ❖ Every 12 months in non-contaminated and non-freezing environments.
- ❖ Every 6 months in contaminated or freezing environments.
- ❖ After every job for gunite, hydroblasting, or sandblasting.

WIRE ROPE INSPECTION

Field Inspection

Inspection **must** be performed by a competent person.

Inspection Frequency

Inspect **ALL** wire ropes at the start of each work shift and after any occurrence that could affect a wire rope's integrity. The entire length of the wire rope should be inspected.

Wire Rope Replacement (mandatory)

Wire ropes **MUST** be replaced if **ANY** of the following conditions exist.

- ❖ Any physical damage which impairs the function and/or strength of the wire rope.
- ❖ Kinks that might impair the tracking and/or wrapping of the wire rope around the drum or sheave of the hoist.
- ❖ Six randomly distributed wires broken in one rope lay, or three broken wires in one strand in one rope lay.
 - Although, OSHA regulations allow some broken wires, Sky Climber recommends that wire rope be replaced if a single broken strand is found.

- ❖ Loss of more than one-third of the original diameter of the outside wires due to abrasion, corrosion, scrubbing, flattening, or peening.
- ❖ Heat damage caused by a torch, or any damage caused by contact with electrical wires.
- ❖ Damage caused by improper grounding when welding from a suspended platform.
- ❖ Evidence that the secondary brake has been activated during an over speed condition and has engaged the suspension rope.

Examples of wire rope defects that require the rope to be replaced

Broken or damaged tips



Broken strands



Crushing



Kinking



“Milking”



Heat, Chemical or Electrical damage



Bird caging



CHECKLISTS

CHECK DAILY or before the start of each shift:

Cornice Hook

- ❖ Substantial structure for hook and tieback point
- ❖ Tieback at proper angle
- ❖ Check fist grip torque (5/16" – 30 ft. lbs.; 3/8" – 45 ft. lbs.)
- ❖ Bearing block in place
- ❖ Warning and rating labels in place and legible
- ❖ Capacity equal to or greater than hoist rated working load
- ❖ Spacing of hooks equal to hoist spacing

Parapet Clamp

- ❖ Substantial structure for clamp and tieback
- ❖ Wall surfaces parallel (vertical)
- ❖ Tieback at proper angle
- ❖ Check fist grip torque (5/16" – 30 ft. lbs.; 3/8" – 45 ft. lbs.)
- ❖ Warning and rating labels in place and legible
- ❖ Capacity equal to or greater than hoist rated working load
- ❖ Spacing of clamps equal to hoist spacing

Rolling Roof Rigs

- ❖ Tieback at proper angle to substantial structure
- ❖ Check fist grip torque (5/16" – 30 ft. lbs.; 3/8" – 45 ft. lbs.)
- ❖ Load on jacks – not casters
- ❖ All hardware in place and properly torque
- ❖ Warning and Rating labels in place and legible
- ❖ Counterweights – correct amount, properly attached
- ❖ Beam reach limit not exceeded for hoist rating
- ❖ Spacing of beams equal to hoist spacing

Tank Top

- ❖ Tieback to substantial structure
- ❖ Check fist grip torque (5/16" – 30 ft. lbs.; 3/8" – 45 ft. lbs.)
- ❖ Make sure roller is seated properly
- ❖ Warning and Rating labels in place and legible
- ❖ Make sure roller rating is equal to or greater than hoist capacity

Ring Girder Roller

- ❖ Tieback to substantial structure
- ❖ Check fist grip torque (5/16" – 30 ft. lbs.; 3/8" – 45 ft. lbs.)
- ❖ Make sure roller is seated properly
- ❖ Warning and Rating labels in place and legible
- ❖ Make sure roller rating is equal to or greater than hoist capacity

Rigging Slings

- ❖ Make sure sling is attached to a substantial structure (4:1 Safety Factor)
- ❖ Check fist grip torque (5/16" – 30 ft. lbs.; 3/8" – 45 ft. lbs.)
- ❖ Make sure rope is protected at chafing points
- ❖ Make sure rope is protected at break points

CHECKLISTS (Continued)

CHECK DAILY or before the start of each shift:

Permanent Davits – Daily Check

- ❖ Make sure davit has been inspected and tested prior to use
- ❖ Make sure davit is installed per manufacturer's instructions
- ❖ Make sure capacity is equal to or greater than hoist capacity
- ❖ Check fist grip torque (if used)

Counterweights – Daily Check

- ❖ Must be designed for use as counterweight
- ❖ Make sure they are securely attached to beam
- ❖ Make sure they are made from a non-flammable material
- ❖ Make sure they are labeled individually. Sky Climber counterweights are 50 lbs.



WARNING

Do NOT use Sky Climber Hoists, Sky Locks, or any equipment that is damaged or worn beyond normal tolerances.

Ascertain that:

- ✓ *Instructions are kept with the unit at all times. Additional copies are available – contact Sky Climber.*
- ✓ *All Warning and Rating labels are in place, legible, and have been read.*
- ✓ *Hoist Drain Holes on the bottom are open. Fasteners checked.*
- ✓ *Suspended Platform Hoist is connected to proper power source.*
- ✓ *Minimum of 3 J-Clamps are used and are tight. (4 J-Clamps are required for round thimbles).*
- ✓ *Cornice Hook, Parapet Clamps or Outriggers, and similar rigging are secured and tied back. Chokers or similar devices are securely in place. Tie backs are tight and straight back.*
- ✓ *Counterweights are non-flowable type, secure, and correct amount.*
- ✓ *Roof rigging load is spread using 3/4 inch plywood. Hardwood used for Load Spreader with Parapet.*
- ✓ *Wire rope inspected and is not kinked, bird-caged, or otherwise damaged.*
- ✓ *The wire rope bitter end is looped and secured with a J-Clamp.*
- ✓ *Sky Lock, Hoist Load, Controlled Descent, and Emergency Stop tests performed and acceptable.*

