

SKY CLIMBER®

Upgrade
your
hoist

Compact Hoist ROLLER Upgrade Kit

Our hardworking Compact Hoists now feature a new roller design for gearboxes that makes them gentler on wire rope while reducing annual maintenance time.

Owners of original Compact Hoist models can reap the benefits of this design improvement with a simple upgrade kit.

Benefits

This upgraded gearbox is easier and faster to maintain and extends the life of wire rope when it's used. This design seats rope into the sheave with spring pressure for optimal movement without placing undue pressure on wire rope.

Plus, the subassembly is modular, making service and maintenance faster and easier.

Available for all Compact Models

This Compact Hoist Roller Upgrade is available for all Sky Climber Compact Hoists, including Electric and Pneumatic (Air) models. Contact Sky Climber and reference part number **42009051-K** to order.

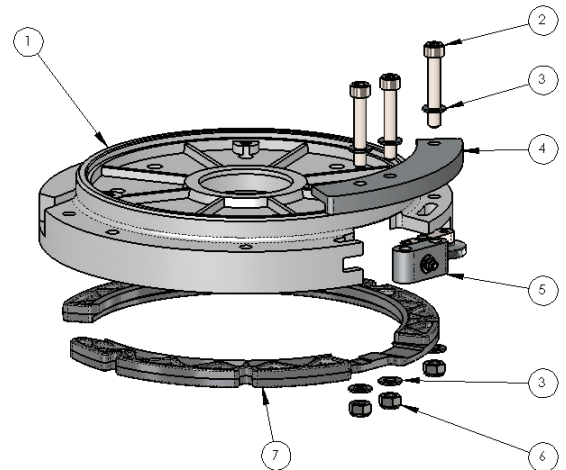

Kit (42009051-K) Components

Component	Quantity
1 Compact Modified Cover	1
2 Socket head cap screw	3
3 Special Washer	6
4 Compact Roller Cover	1
5 Assembly Tilt Roller	1
6 Nut	3
7 Guiding Rings	1



Pre-upgraded models available

Want new hoists with this upgrade already installed? Contact us today and reference the part numbers below:

Upgraded Complete Hoists

Component	Part No.
Compact Electric 750 with Roller Upgrade	KCER-750-110
Compact Electric 1000 with Roller Upgrade	KCER-1000-208
Compact Electric 1250 with Roller Upgrade	KCER-1250-208
Compact Electric 1500 with Roller Upgrade	KCER-1500-208
Compact Air 1000 with Roller Upgrade	KCAR-1000-AIR-G
Compact Air 1250 with Roller Upgrade	KCAR-1250-AIR-G

800.255.4629 | Info@SkyClimber.com

W W W . S K Y C L I M B E R . C O M