

# Barge Access Trolley & Workcage

## Port of South Louisiana

**Application:** Powered trolley and workcage for inspection of cement barges at industrial import facility



### Flexible system for vessel inspections

Built for an international cement company, this powered trolley and workcage system is ideal for use in many scenarios.

For this project, the customer needed a new solution to repeatedly transport workers from a busy marine terminal structure down over the river and onto floating barges for inspection and maintenance.

Sky Climber product teams developed a system based on a Compact Electric Hoist, powered trolley, and work basket that would work with an existing I-beam. The system allows workers to traverse the length of the rotating beam, downward into the barge and then back up. This user-friendly configuration makes routine barge inspections safer and is versatile enough to use in a variety of other applications.

#### System Details

1,000 lb Compact Electric hoist

Winder assembly with 2 drums

Rider and Operator Controls

Work cage with swinging gate

Drop Length: up to 250 feet  
(80 ft in this application)

Trolleys: 1 powered , 1 unpowered  
(configurable to fit variety of I-beams)

**800.255.4629 | [Info@SkyClimber.com](mailto:Info@SkyClimber.com)**

Sky Climber LLC, 1800 Pittsburgh Drive, Delaware, Ohio 43015

# Barge Access Trolley & Workcage

## Port of South Louisiana

### Safe, versatile

Prior to the development of this system, the customer used non-OSHA compliant ladders, and non-man-rated air tuggers to raise and lower workers in and out of the barges. This made routine inspections, cleaning and maintenance work hazardous and unsafe.

This system utilizes an OSHA-compliant Compact Electric Hoist, which allows the Operator / Rider to control the hoist with a wireless remote. Plus, with our patented Sky Lock technology and emergency descent feature for lowering during power failure, this system makes traversing in and out of barges and other vessels considerably safer.

### Additional applications

This barge access powered trolley system is ideal for any ship-hold or barge inspection applications. Each time a cargo hold is emptied before refilling, whether with cement, gravel, sand, grain, etc., this system will quickly and safely deliver workers to and from the vessel with ease.

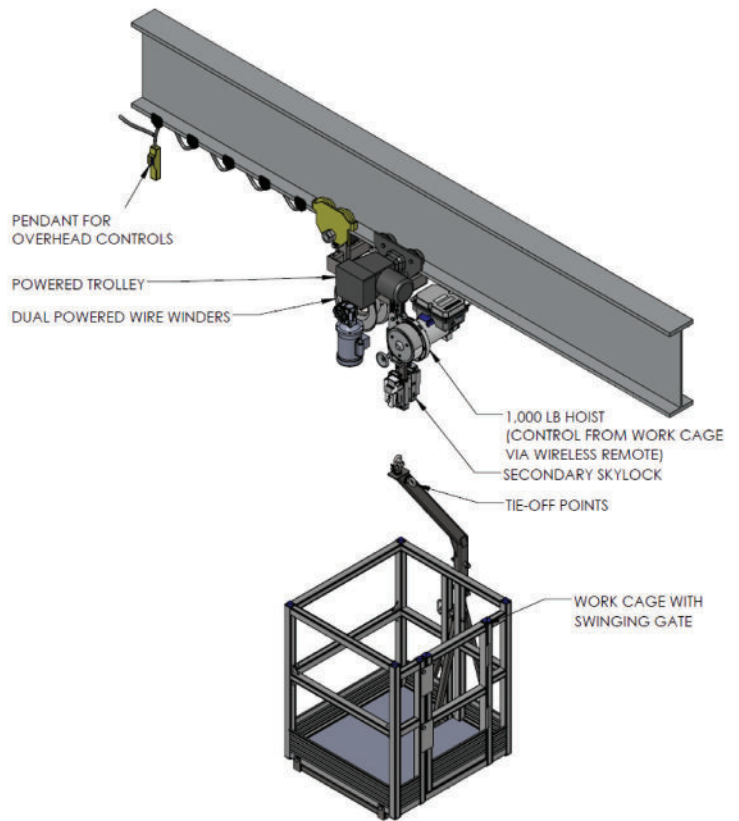

Controls	
Rider Controls:	<ul style="list-style-type: none"> <li>• 2-button remote control in basket.</li> <li>• Suspended pendant operates trolley in/out and boom rotation</li> </ul>
Operator Controls:	All controls on push button panel

Hoist Specifications	
Compact 1000, 220 v, single phase	
<i>(208 v single phase or 3 phase could also be accommodated)</i>	
Line Current: 15 Amps	
Live load: 500 lbs	

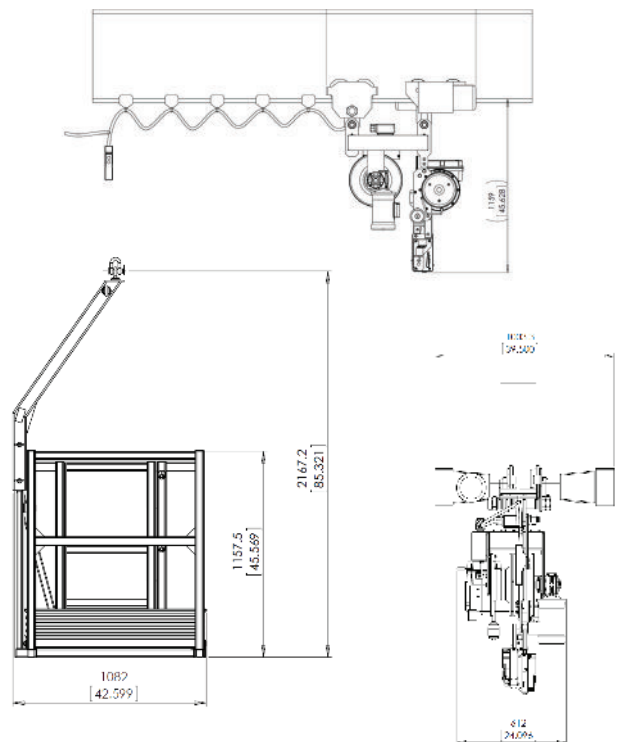

**800.255.4629 | [Info@SkyClimber.com](mailto:Info@SkyClimber.com)**

Sky Climber LLC, 1800 Pittsburgh Drive, Delaware, Ohio 43015