

NOTES:
1. DIMENSIONS SHOWN IN [XX] ARE FOR REFERENCE ONLY.

ITEM NO.	PART NUMBER	DESCRIPTION	3523300 LEFT/QTY.
1	360043	FLOOR PANEL - 3 METER	1
2	360035	3 METER SIDE PANEL	2
3	360149	TOP RAIL ASSEMBLY, 3 METER	2
4	3523- 3M TRIP BAR	3M TRIP BAR	1
5	360039	CONNECTION FRAME WELDMENT	2
6	360054	TELESCOPING POST WELDMENT	4
7	3523- CASTER TRIP BAR	TRIP BAR ASSEMBLY	2
8	3523- HOIST AND MOUNT	HOIST AND MOUNTING SYSTEM	1

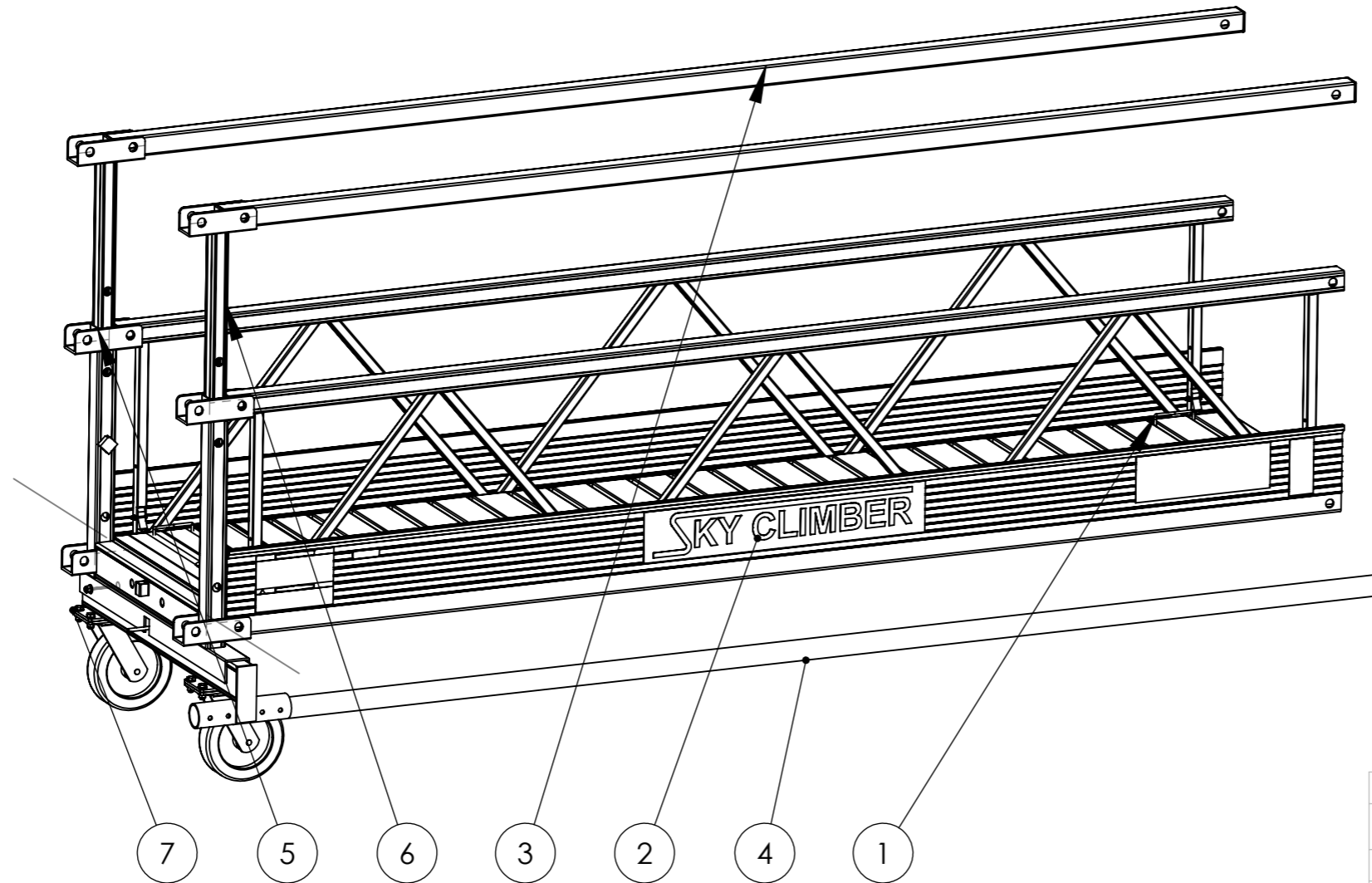

DEBUR AND BREAK SHARP EDGES		
MATERIAL		
TREATMENT		NOTICE THE INFORMATION CONTAINED IN THIS DRAWING IS THE SOLE PROPERTY OF SKY CLIMBER. ANY REPRODUCTION IN PART OR WHOLE WITHOUT THE WRITTEN PERMISSION OF SKY CLIMBER IS PROHIBITED.
FINISH		
WEIGHT		3 METER MID SECTION
KG		
APPROVALS	DATE	UNLESS OTHERWISE STATED DIMENSIONS ARE IN MM [INCH]
DRAWN BY		
CHECKED BY		TOL. ISO 2768-m > 0,5 6 30 120 400 < 6 30 120 400 TOL. ±0.1 ±0.2 ±0.3 ±0.5 ±0.8
APPROVED BY		MACHINED SURFACES 12,5
RAW MATERIAL NO.		ISO 1302 FIRST ANGLE PROJECTION SCALE
CAD GENERATED DRAWING. DO NOT MANUALLY UPDATE.		DWG. NO. 3523600 SIZE B/A3 DO NOT SCALE DRAWING. SHEET 1 OF 2

NOTES:
1. DIMENSIONS SHOWN IN [XX] ARE FOR REFERENCE ONLY.

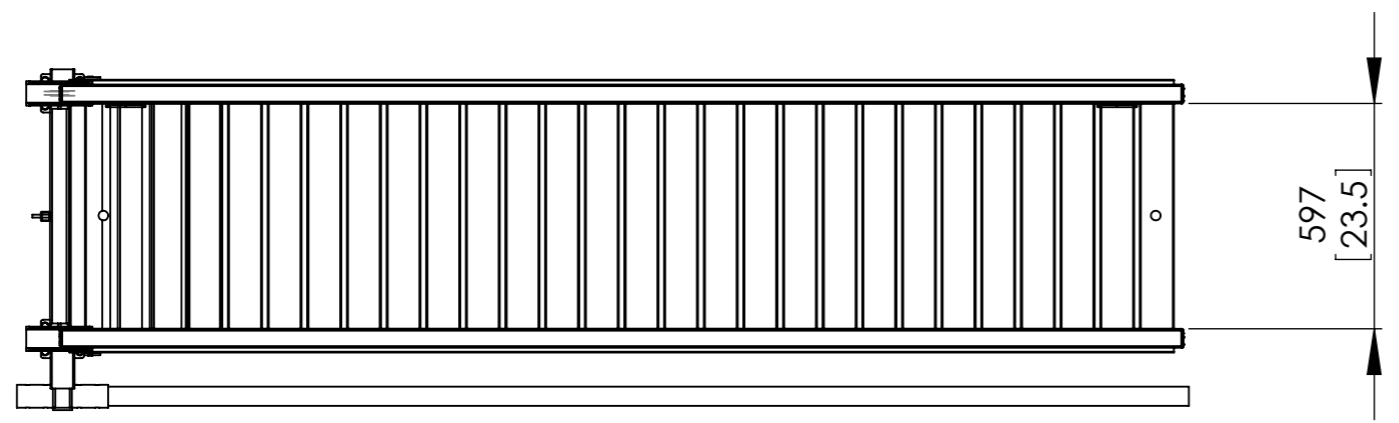
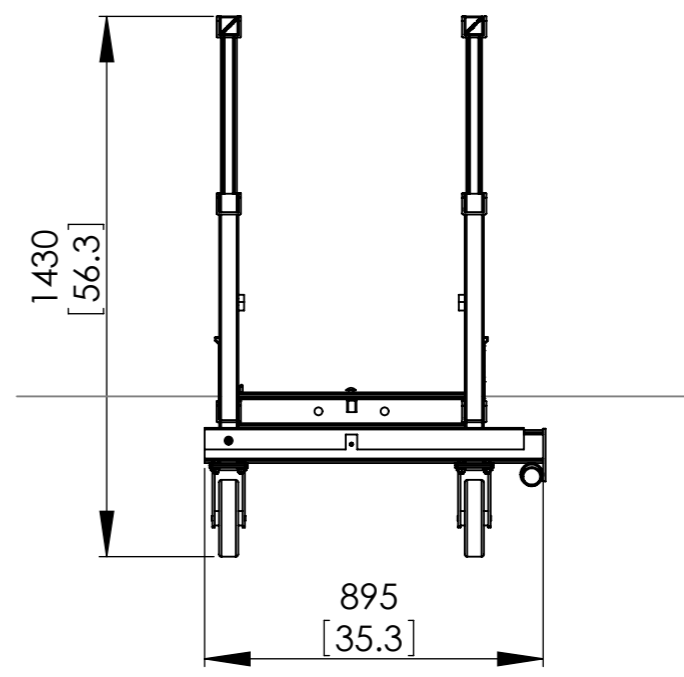
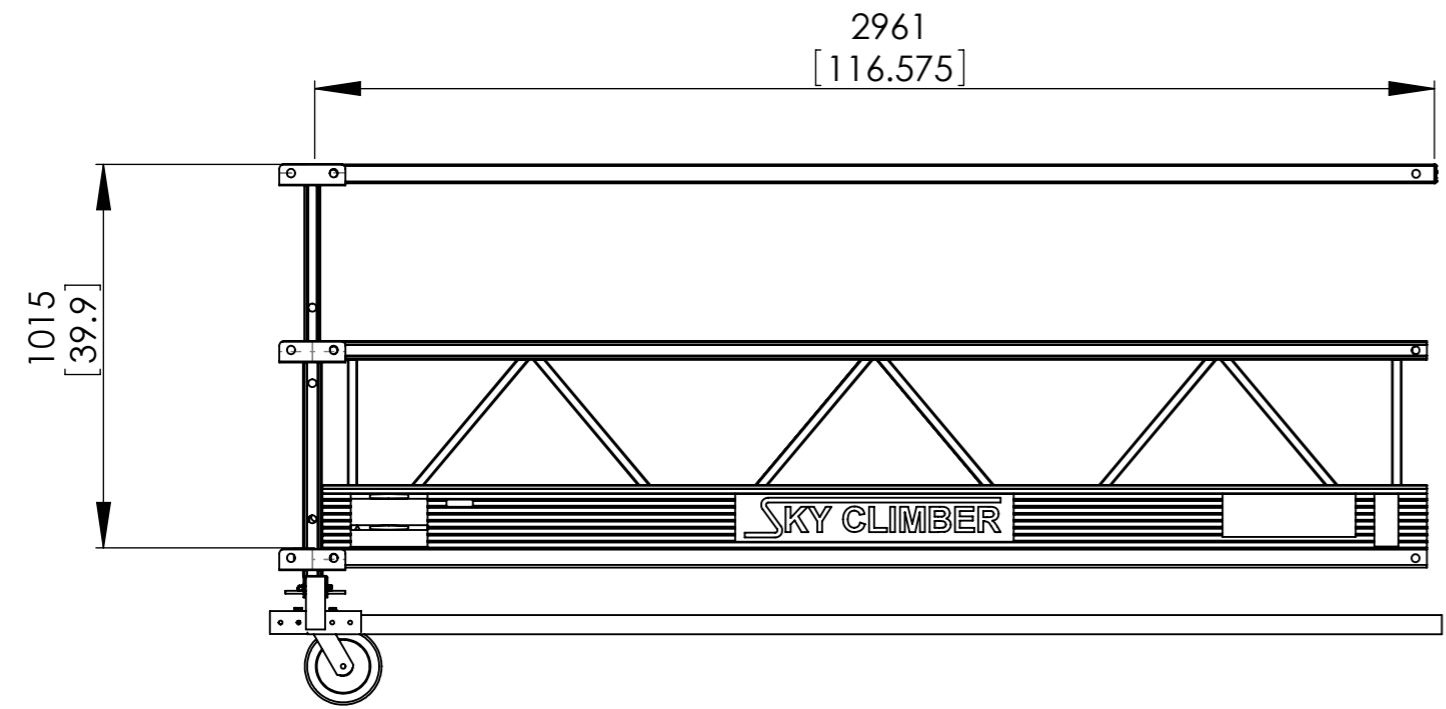

NOTICE
THE INFORMATION CONTAINED IN THIS DRAWING IS THE SOLE PROPERTY OF SKY CLIMBER. ANY REPRODUCTION IN PART OR WHOLE WITHOUT THE WRITTEN PERMISSION OF SKY CLIMBER IS PROHIBITED.

3 METER MID SECTION

CAD GENERATED DRAWING. DO NOT MANUALLY UPDATE.	FIRST ANGLE PROJECTION	SCALE 1:20	DWG. NO.	REV.
			3523600	
SIZE B/A3		DO NOT SCALE DRAWING.		SHEET 2 OF 2